



JINDAL

INFINITY REBARS

THAT LAST FOR CENTURIES



A LEGACY BUILT ON SAFETY & TRUST

Founded by Shri O.P. Jindal in 1970, Jindal Stainless is one of the largest stainless steel conglomerates in India and ranks amongst the top 10 stainless steel conglomerates in the world. Jindal Stainless Group has an annual crude steel capacity of 3 MTPA and an annual turnover of 4.2 Billion USD (as on March 2023).

Our growth has been backed by the excellence of our people, value-driven business operations, customer centricity, adoption of one of the best safety practices in the stainless steel industry and a commitment to social responsibility.



STATE OF THE ART R&D AND MANUFACTURING PROCESSES

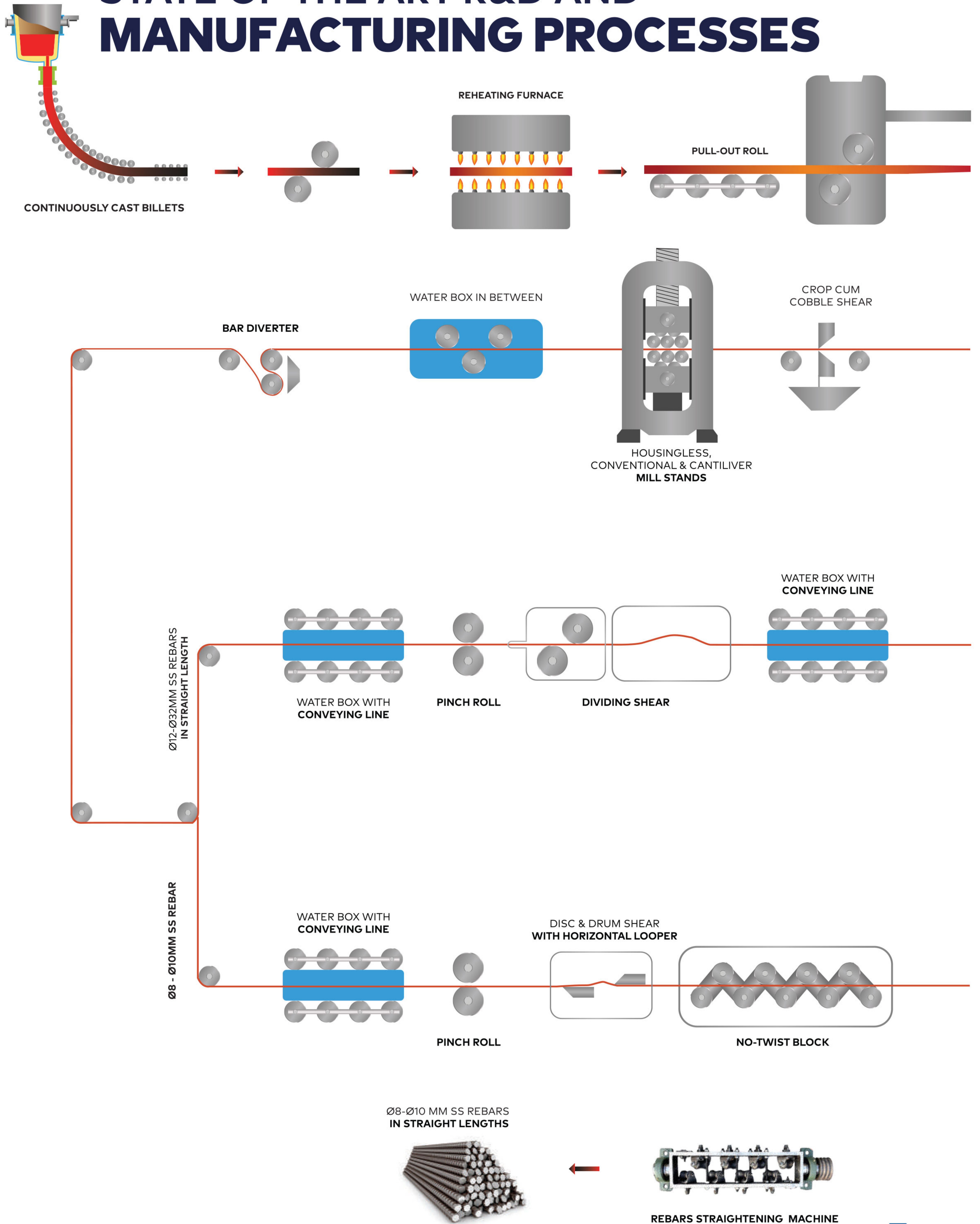

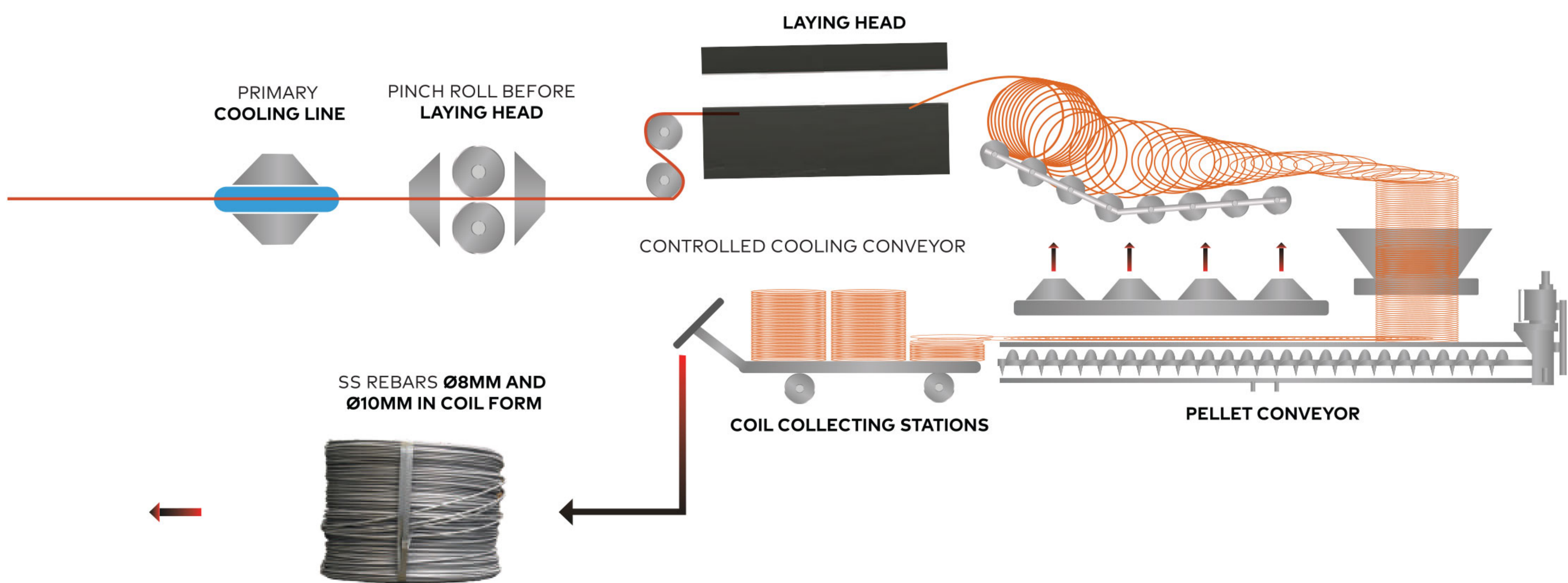
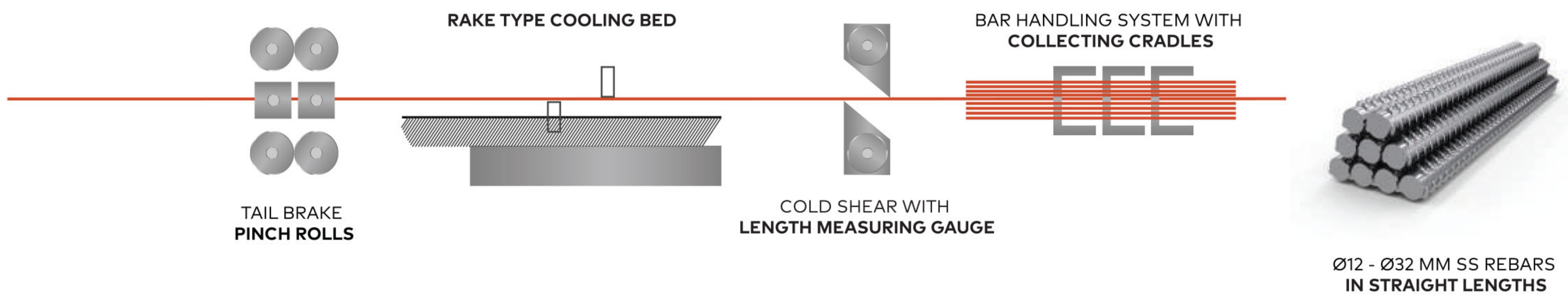
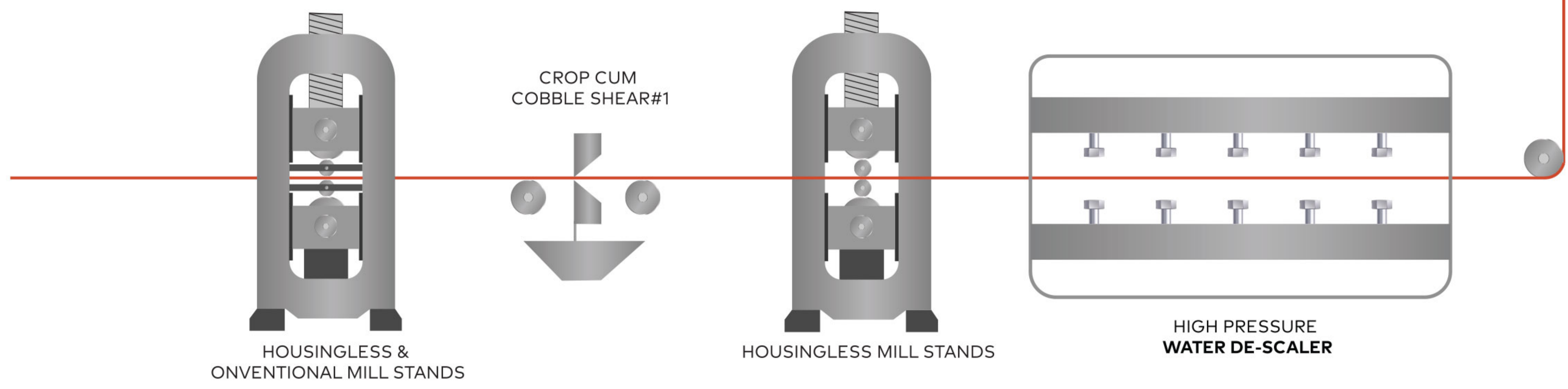
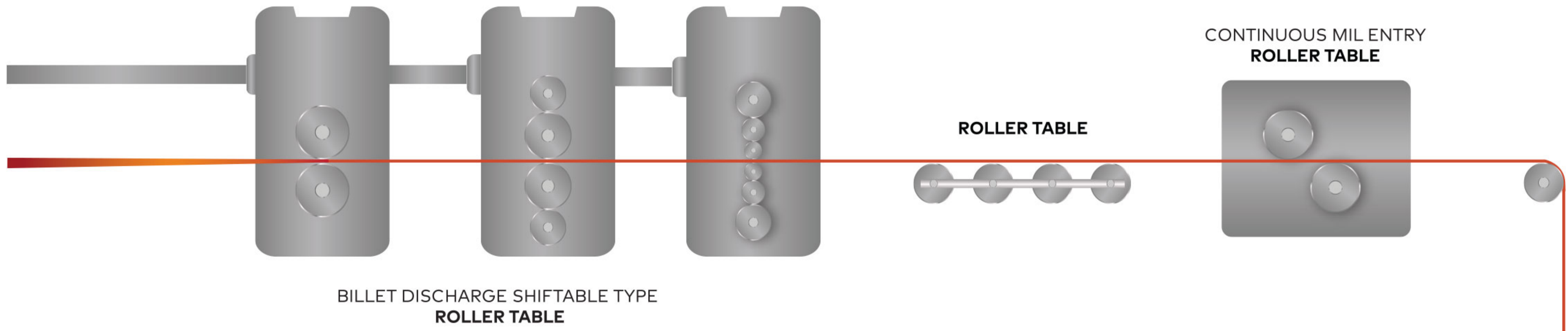

PRODUCT SPECIFICATIONS

Chemical Composition of SS Rebar Grade G (410 L) as per IS 16651:2017:

Chemical	C	Ni	Mn	Si	P	S	Cr	N
Min %							11	-
Max %	0.03	0.6	1	1	0.04	0.03	13.5	-

Mechanical Properties of High Strength Deformed Stainless Steel Bars and Wires as per IS 16651:2017:

S. No.	Properties	SS 500	SS 550	SS 600	SS 650
1	0.2 percent proof stress (Rp0.2), Min, N/mm ²	500	550	600	650
2	Percentage elongation after fracture (A5), Min, on gauge length $5.65 \sqrt{A}$, where A is the cross-sectional area of the test piece	16	14.5	10	10

Product Offering:

Diameter (mm)	8 mm to 32 mm
Standard Length	12 mtrs.

PLANT CAPACITY – 1,80,000TPA



**THE PERFECT BLEND OF
STRENGTH & DURABILITY TO
COMPLEMENT PROGRESS**

**INTRODUCING
JINDAL INFINITY REBARS**

NEED FOR STAINLESS STEEL REBARS

Stainless steel rebars play a pivotal role in modern construction owing to their exceptional corrosion resistance and durability. Unlike conventional carbon steel rebars, stainless steel rebars offer extended service life in structures exposed to corrosive environments such as marine settings, chemical plants and infrastructure in coastal areas. Their resistance to rust and corrosion helps maintain the structural integrity of buildings and bridges over time, significantly reducing maintenance costs and the need for frequent repairs. These rebars contribute to enhanced safety and reliability in construction, ensuring structures remain robust and stable for longer periods while minimizing environmental impact through their recyclability, making them a sustainable choice for infrastructure development worldwide.

OTHER ADVANTAGES:

- It is highly resistant to corrosion from chloride ion
- It does not rely on the high alkalinity of concrete for protection
- Concrete cover can be reduced
- Concrete sealant, such as Silane, can be eliminated
- Concrete mix can be simplified to suit concrete design needs, not for rebar protection needs
- It improves durability
- It reduces maintenance and repair
- It can be used selectively for high risk elements cost-effectively
- It will eventually be recycled



TYPE OF STAINLESS STEEL THAT CAN BE USED IN THE REINFORCEMENT OF CONCRETE

There exists a diverse array of stainless steel alloy options for choosing rebars, designed to fulfill specific mechanical design requirements and anticipated environmental corrosiveness. Stainless steels encompasses primarily five main groups: Austenitic, Ferritic, Duplex, Martensitic, and Precipitation-hardened steels. The selection of SS REBAR GRADE G Stainless Steel as a preferred material depends on various factors, including its corrosion resistance, expected longevity and life cycle cost, ensuring it aligns well with the intended application and structural demands.

SS REBAR GRADE - G(410L) Conforming to IS 16651:2017 is currently used in various project by different Govt. bodies in India including :

- **INDIAN RAILWAYS**
- **NHAI**
- **PWDs**
- **MMRDA**
- **MCGM**
- **MRIDCL**

SS REBAR GRADE - Conforming to IS 16651:2017 is currently used in various project by different Govt. bodies in India including:

- **Statue of Oneness (Adi Shankaracharya)**
- **RDSO – High Speed Rail Test Track**
- **Pamban Bridge**
- **Dr. Balasaheb Ambedkar Memorial and many more**



Extended Life



Excellent Durability



**Exceptional
Corrosion Resistance**



**Min. Maintenance
Cost**



**Lower Environmental
Footprint**



**Excellent Fire
Resistant**



**Reduction in Life
Cycle Cost**

APPLICATIONS OF STAINLESS STEEL REBARS

HIGHWAY INFRASTRUCTURE

Stainless steel reinforcement finds application in highway infrastructure where corrosion could lead to early degradation of the road system, potentially causing significant economic consequences for the local community. Utilizing stainless steel allows the builder to essentially complete the construction efficiently, avoid subsequent repairs, and ensure long-term durability. Employing stainless steel reinforcement substantially extends the useful lifespan of the infrastructure, minimizing the need for frequent repairs or replacements.



- BRIDGE STRUCTURE ELEMENTS
- DECK PANELS
- BARRIER WALLS AND CURBS
- SIDEWALKS AND MEDIANS
- DECK JOINT BLOCKOUTS
- ABUTMENTS, ROOF SLABS, APPROACH SLABS AND WING WALLS
- BRIDGE PIERS AND PIER CAPS
- BARS PROJECTING FROM PRECAS
- ANCHORING SYSTEMS
- TUNNELS
- ALL OTHER CHLORIDE SPLASH ZONES
- HIGHWAY ELEMENTS
- LOAD TRANSFER DOWELS
- CONCRETE PAVEMENTS



MARINE INFRASTRUCTURE

Stainless steel reinforcing is used for structures in a marine environment where corrosion could be an acute design challenge. By using stainless steel reinforcing, the useful life of marine structures is dramatically increased.

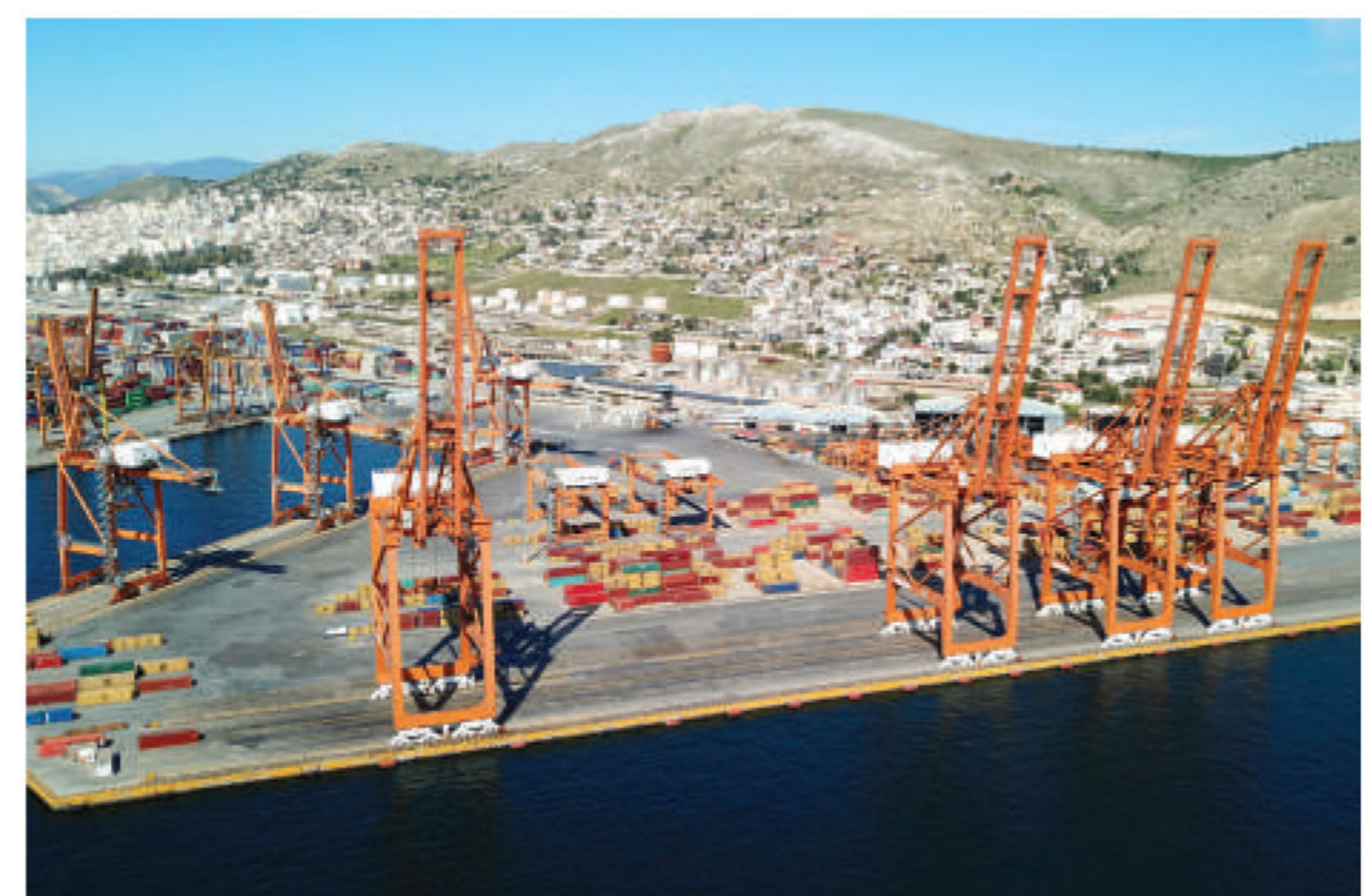

- MARINE STRUCTURES
- COASTAL BRIDGES
- PIERS
- WHARVES
- TUNNELS

OTHER APPLICATIONS

BRIDGES	DAMS	RAILWAY WASHING LINES
SEA WALLS	NUCLEAR WASTE STORAGE TANKS	DOCKYARDS
WASTE WATER TANKS	HIGH RISE BUILDINGS	



GLOBAL NETWORK



- INTERNATIONAL SALES OFFICES
- MANUFACTURING FACILITIES

LEADING STAINLESS STEEL MANUFACTURER IN THE WORLD



CONTACT OUR EXPERT FOR ENQUIRIES:

Kunj Gupta - 80542 28667

Group Email ID - jsl.rebars@jindalstainless.com

Website: www.jindalstainless.com